

NORTH AMERICAN MODEL

# TWISTER

T 4 TRIM SAVER



USER MANUAL

PN: 21-00-000426\_REV04



TWISTERTRIMMER.COM



# TABLE OF CONTENTS

Important Safety Information	2
Parts and Tools	5
Assembled Trim Saver	9
Assembly	10
Inspections	19
Cleaning	20
Troubleshooting	24
Warranty Information	25
Specifications	28
Spare Parts and Accessories	29
Contact Us	30

# IMPORTANT SAFETY INFORMATION

This manual is for the Twister T4 Trim Saver vacuum. In this manual, the Trim Saver vacuum will simply be referred to as the Trim Saver.

The Trim Saver is a high-speed and high-powered vacuum. It requires special safety precautions to be practiced during assembly and operation to reduce the risk of personal injury. Read this manual, including all important safety information, danger, warning, and caution signs before assembling and using the Trim Saver.

Keirton is continually improving all its products. As a result, engineering changes are sometimes made. If appearances differ from this manual, please contact Keirton Technical Support for assistance (see **Contact Us** on page 30).

Do not allow anyone to assemble or use the Trim Saver without this manual. A first-time assembler or user of the Trim Saver should obtain proper instruction from this manual.

## General Safety Information

- Do not tamper with or bypass the Trim Saver's safety systems. **Failure to abide could cause fatal injury.**
- Do not assemble or operate the Trim Saver while tired or under the influence of drugs, alcohol, or medications.
- Do not wear loose clothing or jewellery when assembling or operating the Trim Saver.
- Confine long hair when assembling or operating the Trim Saver.
- Do not assemble, move, or clean the conveyors while power is connected to them.
- Do not remove safety labels from the machine. **Replace any safety labels if they become damaged or obscured.**
- Keep visitors and children a safe distance from the conveyors.



## DANGER

**CARELESS USE OF THE TRIM SAVER OR ASSEMBLING IT WITHOUT READING THE INSTRUCTIONS AND ACCOMPANYING DANGER, WARNING, AND CAUTION NOTICES MAY RESULT IN SERIOUS OR FATAL INJURY.**

## Connection and Electrical Safety Information

- The Trim Saver requires a 120V, 15A circuit breaker.
- The Trim Saver must be used in connection with a properly grounded receptacle. Refer to **Specifications** on page 20 to determine the correct electrical requirements.
- Observe all applicable building and electrical codes.
- Do not overload outlets as this can result in fire or electric shock.
- Do not use extension cords with a diameter narrower than 12AWG.
- Do not use extension cords longer than 50' (15M).
- To power down the Trim Saver, switch it off using the motor switch before unplugging the machine.
- The motor is not water tight. Do not get the motor wet while cleaning to prevent electric shock.
- Cover the end of the plug before cleaning to prevent electric shock.

## Assembly Safety Information

- Substituting factory parts with third-party parts may result in bodily harm or damage to the Trim Saver.
- Do not skip any assembly steps. Complete all steps in order.
- Do not connect the Trim Saver to a power source until it is fully assembled.
- The motor is heavy and fragile. Use two people to attach it to the rest of the machine.

## Operation and Maintenance Safety Information

- Do not allow anyone to operate the Trim Saver unless it is fully assembled.
- Do not switch on the Trim Saver unless it is connected to the T4 trimmer.
- Do not disassemble the Trim Saver unless it is disconnected from power and the impeller has come to a complete stop. The impeller may continue to spin for up to 30 seconds after stopping the Trim Saver.

# IMPORTANT SAFETY INFORMATION

- Clean the Trim Saver regularly.
- Ensure the Trim Saver is powered off before conducting any maintenance.
- To avoid electric shock, do not attempt to service electrical components on the Trim Saver unless you are a trained electrician.
- Do not attempt maintenance unless directed by Keirton Technical Support.
- Some repair will require a qualified service technician who is trained in machinery maintenance, service, and repair.

Parts: Components

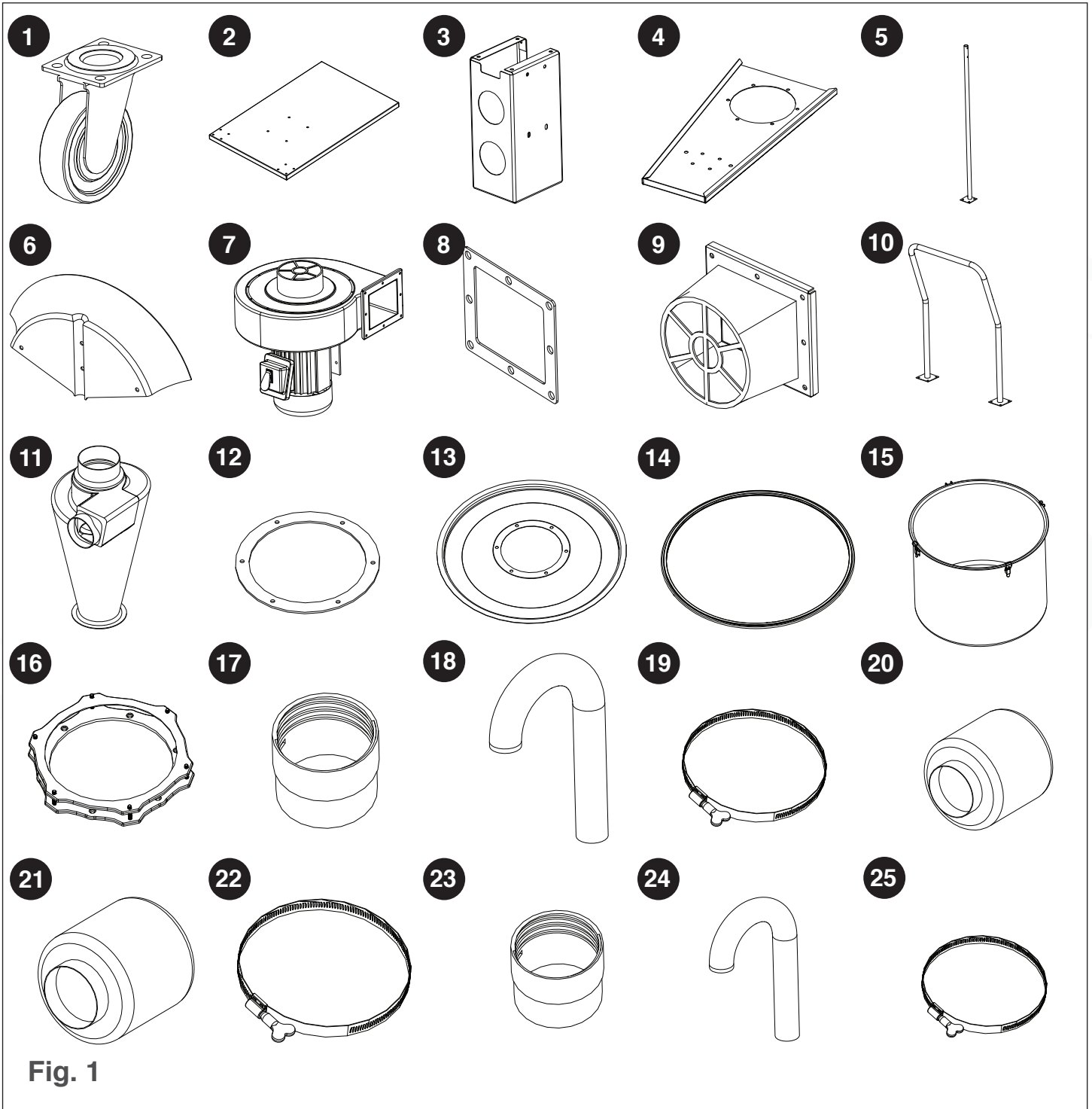

Fig. 1

# PARTS AND TOOLS

Reference	Description	Part Number	Quantity
1	Caster	23-0146	4
2	Base Plate	23-0215	1
3	Motor Support	23-0206	1
4	Lid Holder	23-0208	1
5	Saddle Support	23-0205	1
6	Hose Saddle	23-0198	2
7	1.5hp Vacuum Fan and Motor Assembly	23-0213	1
8	Filter Adapter Gasket	23-0230	1
9	Filter Adapter	23-0209	1
10	Cart Handle	23-0204	1
11	CS-12 Cyclone Assembly	23-0202	1
12	Cyclone/Lid Gasket	23-0241	2
13	Stainless Steel Bin Lid	23-0243	1
14	Lower Lid Gasket	23-0244	1
15	Stainless Steel Bin	23-0242	1
16	Cleaning Flange	11-00-000100 and 11-00-000101	1 (2 pieces)
17	6" Hose Cuff	23-0132	2
18	6" Hose	23-10175A	1
19	6" Hose Clamp	23-01-001152	2
20	200 White Mesh (70 Micron) Filter Bag	23-0246	1
21	300 White Mesh (40 Micron) Filter Bag	23-0247	1
22	7" Filter Bag Clamp	23-0218	1
23	5" Hose Cuff	23-01-002127	2
24	5" Hose	23-01-127675	1
25	5" Hose Clamp	23-01-001127	2



## Parts: Fasteners

The fasteners are placed in labelled bags that pertain to the different stages of assembly. For easiest assembly, do not open these bags until the instructions say to do so.

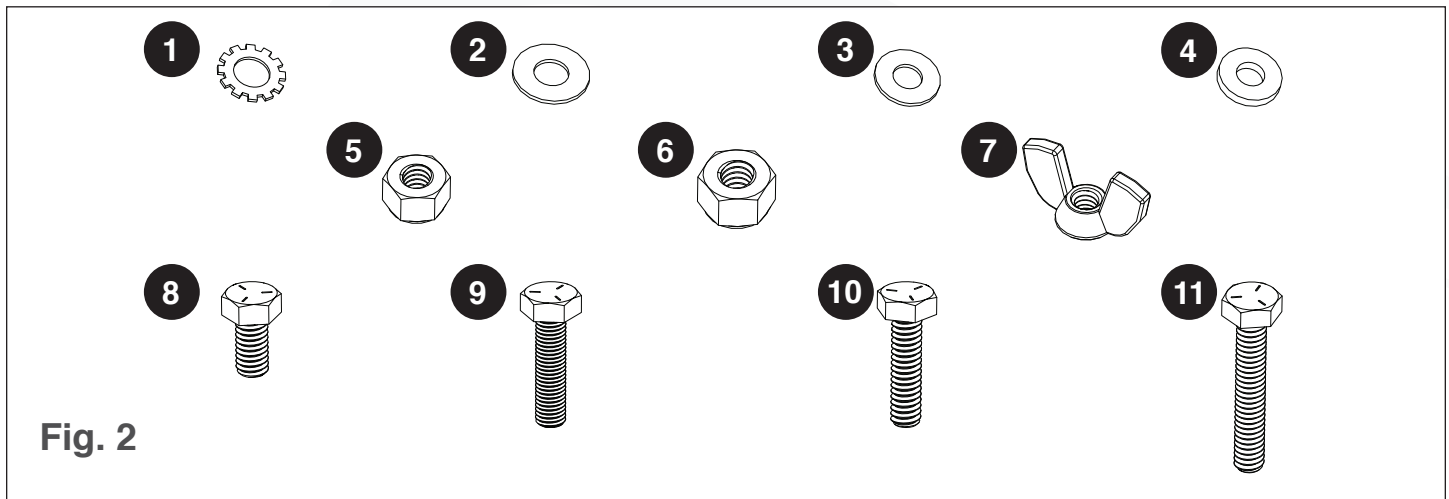
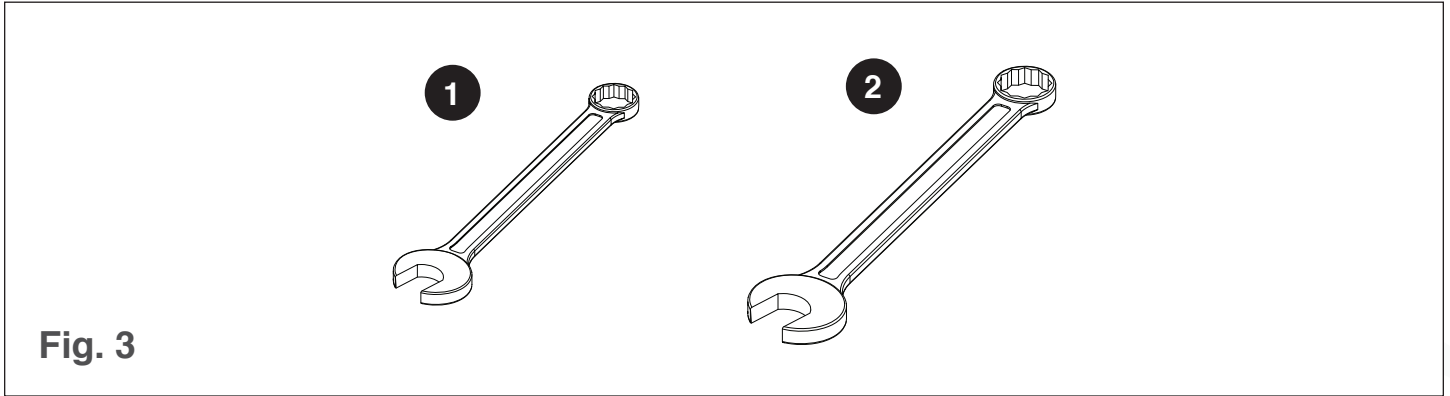

Fig. 2

Reference	Description	Part Number	Quantity
1	5/16" Star Lock Washer	13-02-000411	52
2	5/16" Flat Washer	13-0018	4
3	1/4" Flat Washer	13-02-000014	12
4	1/4" Silicone Washer	23-0248	6
5	1/4"-20 Nyloc Nut	13-0062	6
6	5/16"-18 Nyloc Nut	13-0064	12
7	10-32 Wing Nut (connected to cleaning flange)	13-0168	6
8	5/16"-18 x 5/8" Hex Head Bolt	13-08-516158	46
9	5/16"-18 x 1" Hex Head Bolt	13-08-516110	4
10	1/4"-20 x 1" Hex Head Bolt	13-08-142110	6
11	5/16"-18 x 1.5" Hex Head Bolt	13-08-516115	2

## Tools Needed



Reference	Description	Quantity
1	7/16" Wrench	2
2	1/2" Wrench	2

# ASSEMBLED TRIM SAVER

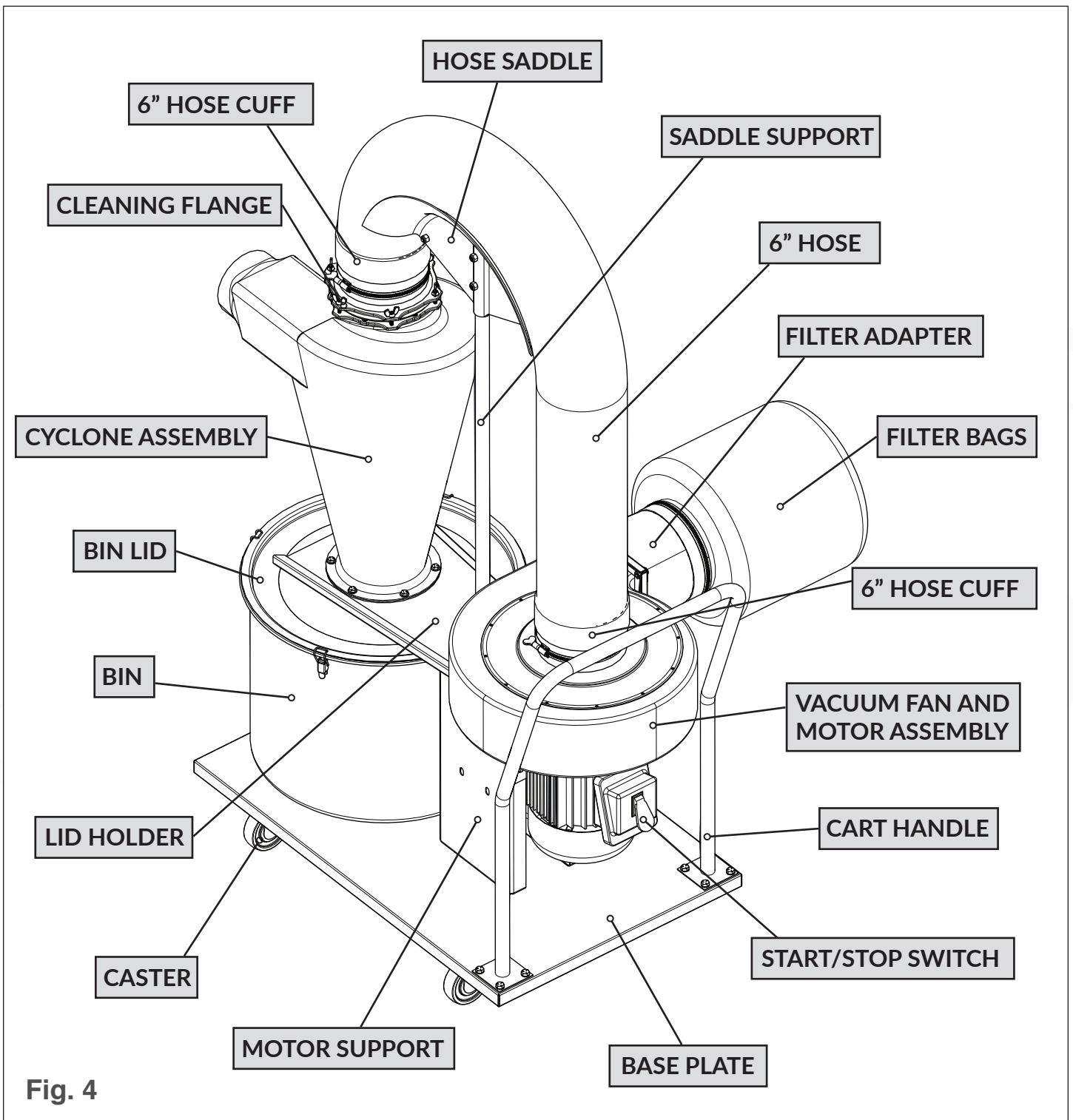

## Step 1: Attach the Casters to the Base Plate

1. Open fastener bag **A**. Bag **A** contains:
  - Sixteen  $\frac{5}{16}$ "-18 x  $\frac{5}{8}$ " Hex Head Bolts
  - Sixteen  $\frac{5}{16}$ " Star Lock Washers.
2. Secure the casters to the base plate using all 16 bolts and star locks washers (see Fig. 5).

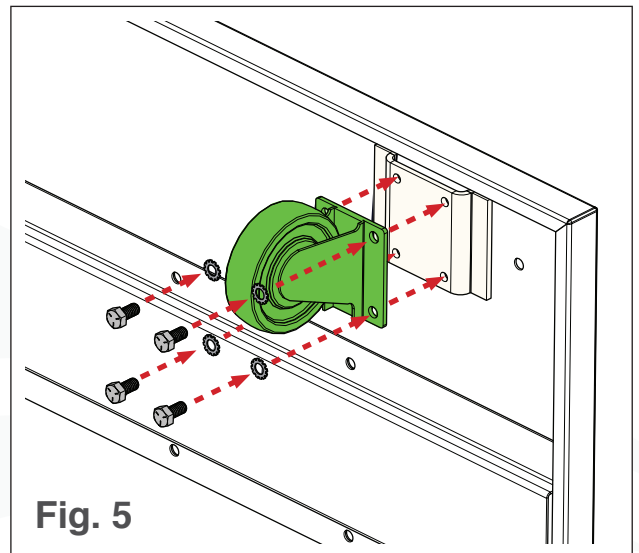

Fig. 5

## Step 2: Attach the Lid Holder to the Motor Support

1. Open fastener bag **B**. Bag **B** contains:
  - Four  $\frac{5}{16}$ "-18 x  $\frac{5}{8}$ " Hex Head Bolts
  - Eight  $\frac{5}{16}$ " Star Lock Washers
  - Four  $\frac{5}{16}$ "-18 Nyloc Nuts.
2. Align the motor support with the narrow end of the lid holder. Ensure the two large holes in the motor support are facing the wide end of the lid holder (see Fig. 6).
3. Place the bolts through four of the star lock washers, then through the lid holder and motor support (see Fig. 6).
4. Secure the remaining star lock washers and nuts over the ends of the bolts (see Fig. 7).

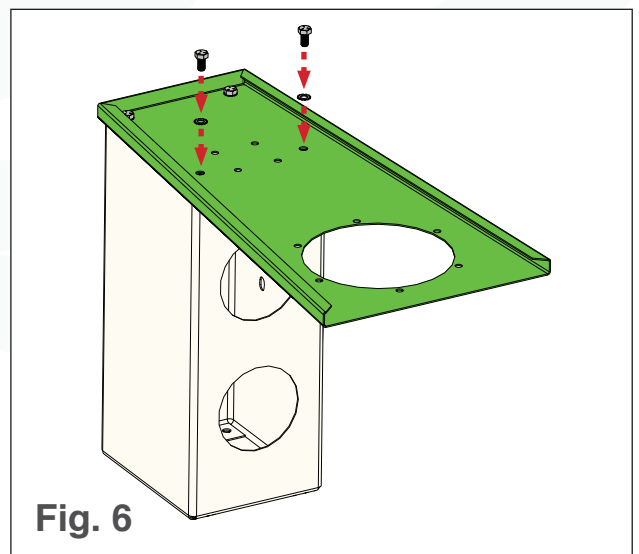
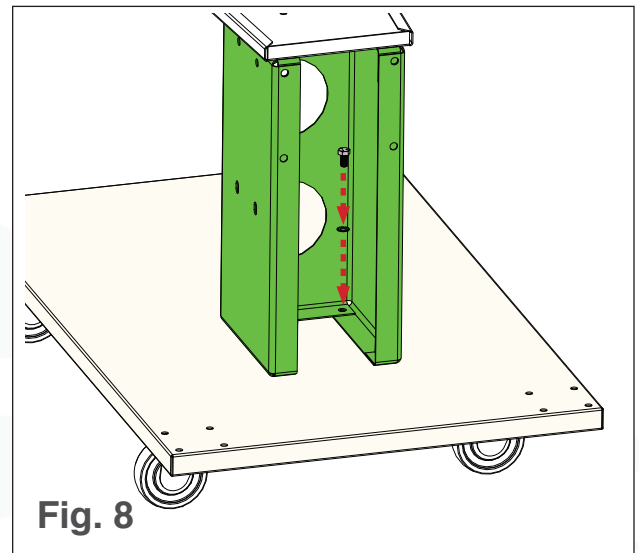
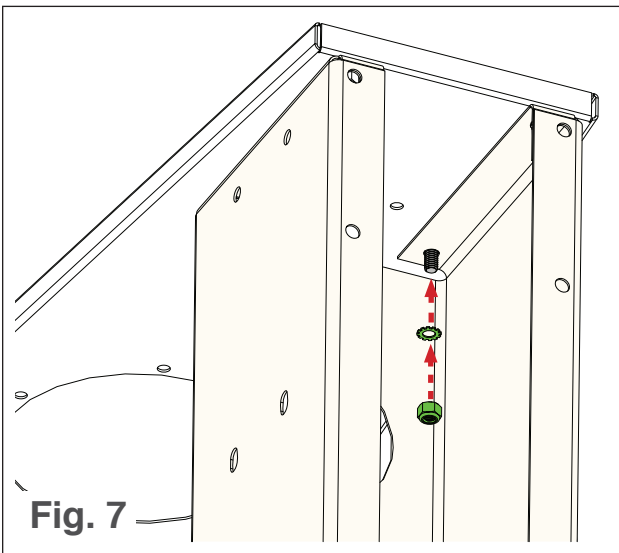

Fig. 6



### Step 3: Attach the Motor Support to the Base Plate

1. Open fastener bag **C**. Bag **C** contains:
  - Four  $\frac{5}{16}$ "-18 x  $\frac{5}{8}$ " Hex Head Bolts
  - Four  $\frac{5}{16}$ " Star Lock Washers.
2. Align the bottom of the motor support with the four off-center bolt holes in the base plate. Ensure the two large holes in the motor support are facing away from the base plate's cart handle bolt holes.
3. Secure the motor support to the base plate using four bolts and star washers (see Fig. 8).

### Step 4: Attach the Saddle Support to the Lid Holder

1. Open fastener bag **D**. Bag **D** contains:
  - Six  $\frac{5}{16}$ "-18 x  $\frac{5}{8}$ " Hex Head Bolts
  - Four  $\frac{5}{16}$ " Star Lock Washers
  - Two  $\frac{5}{16}$ "-18 x 1.5" Hex Head Bolts
  - Four  $\frac{5}{16}$ "-18 Nyloc Nuts.

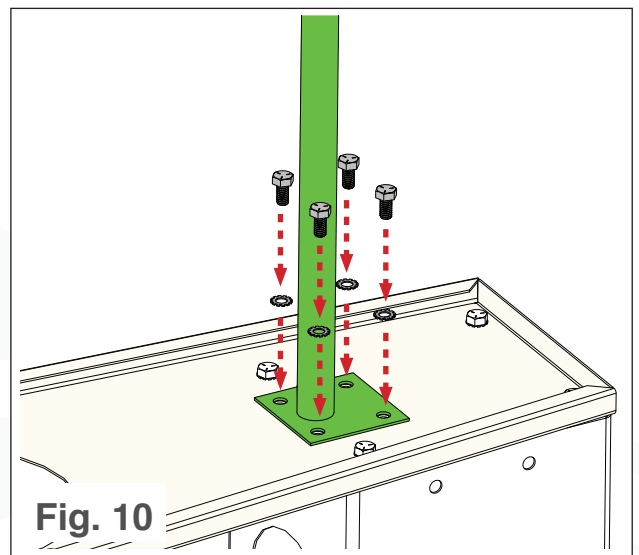
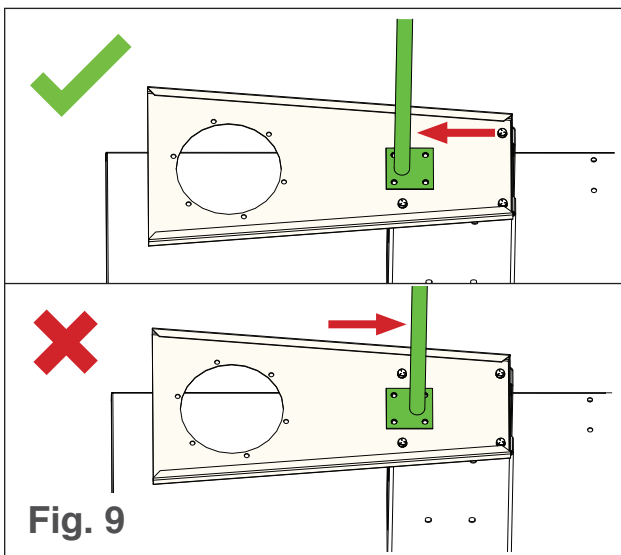

2. Align the base of the saddle support with the lid holder's four center bolts holes. Ensure the pole-side of the base is facing the wide end of the lid holder (see Fig. 9).
3. Secure the saddle support to the base plate using four  $\frac{5}{16}$ "-18 x  $\frac{5}{8}$ " hex head bolts and star washers (see Fig. 10).

## Step 5: Attach the Hose Saddle to the Saddle Support

1. Secure the two hose saddle pieces to the top of the saddle support with the two  $\frac{5}{16}$ "-18 x 1.5" hex head bolts and nuts from bag **D** (see Fig. 11).
2. Place the two remaining  $\frac{5}{16}$ "-18 x  $\frac{5}{8}$ " hex head bolts through the two outer holes, and secure with the two remaining nuts (see Fig. 12).

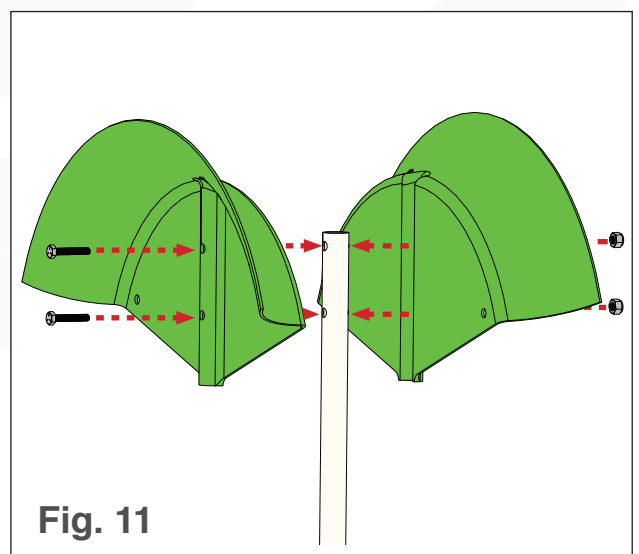

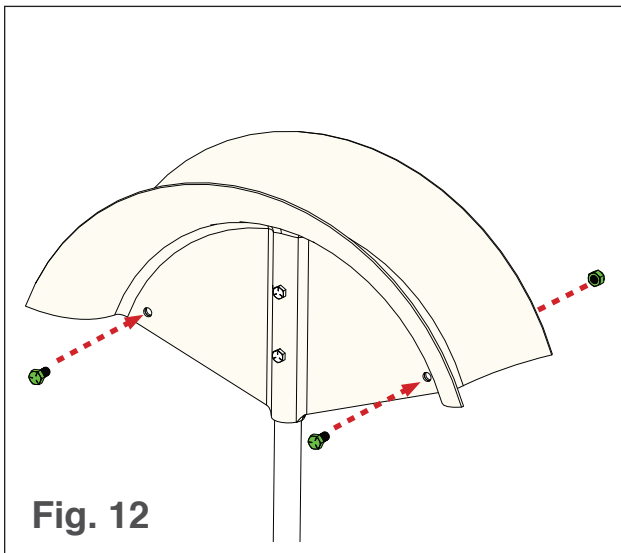

Fig. 12

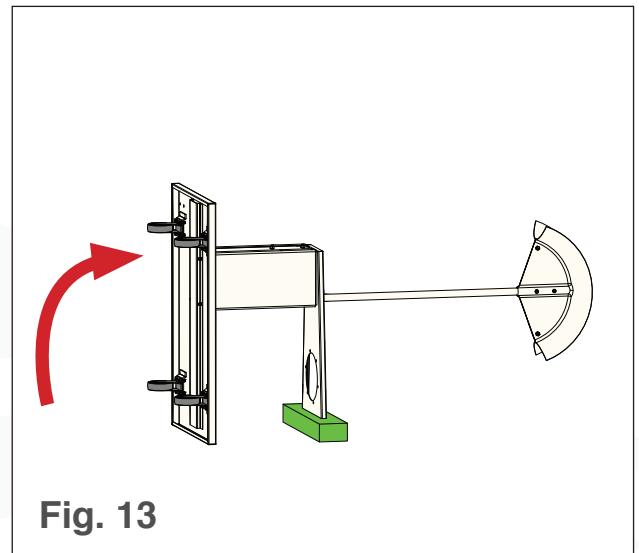

Fig. 13

## Step 6: Attach the Motor Assembly to the Motor Support

The motor assembly is heavy and fragile. Use two people to complete this step.

1. Open fastener bag **E**. Bag **E** contains:
  - Four  $\frac{5}{16}$ "-18 x 1" hex head bolts.
  - Four  $\frac{5}{16}$ " Star Lock Washers
  - Four  $\frac{5}{16}$ " Flat Washers
  - Four  $\frac{5}{16}$ "-18 Nyloc Nuts.
2. Place a piece of foam packaging over the wide end of the lid holder, then rotate the Trim Saver  $90^\circ$  so it rests on the foam (see Fig. 13).
3. Place all four bolts through the flat washers, then through the motor assembly and motor support (see Fig. 14).
4. Reaching through the two large holes in the motor support, secure the star lock washers and nuts over the ends of the bolts (see Fig 15).
6. Rotate the Trim Saver back so it rests on the casters.



### WARNING

THE MOTOR IS HEAVY. USE TWO PEOPLE TO LIFT.



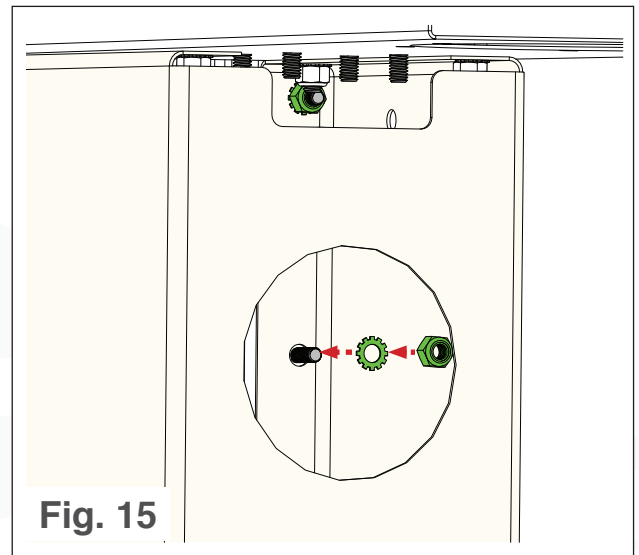
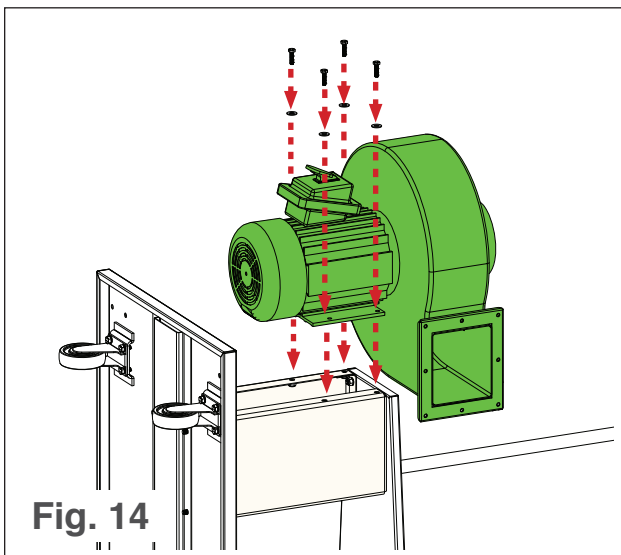

## Step 7: Attach the Filter Adapter to the Motor Assembly

1. Open fastener bag **F**. Fastener bag **F** contains:
  - Eight  $\frac{5}{16}$ "-18 x  $\frac{5}{8}$ " Hex Head Bolts
  - Eight  $\frac{5}{16}$ " Star Lock Washers.
2. Align the filter adapter with the adapter gasket and the motor assembly outlet (see Fig. 16).
3. Secure the filter adapter to the motor assembly with all eight bolts and star lock washers (see Fig. 16).

## Step 8: Attach the Cart Handle to the Base Plate

1. Open fastener bag **G**. Bag **G** contains:
  - Eight  $\frac{5}{16}$ "-18 x  $\frac{5}{8}$ " Hex Head Bolts
  - Eight  $\frac{5}{16}$ " Star Lock Washers.

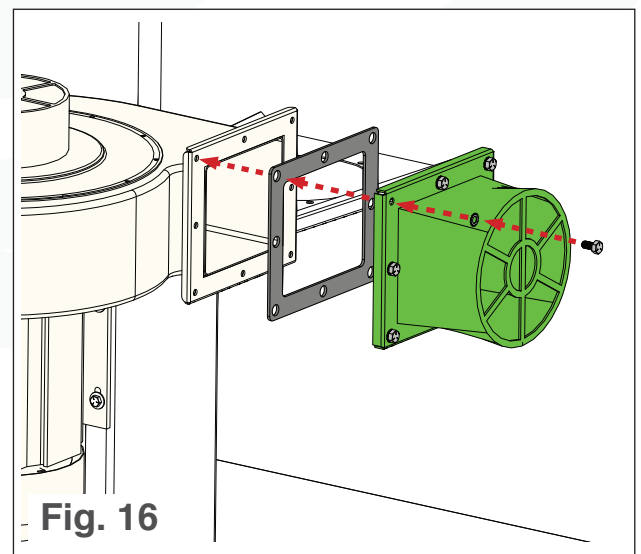



2. Align the cart handle with the base plate so the top of the handle leans away from the motor assembly.
3. Secure the cart handle to the base plate with all eight bolts and star lock washers (see Fig. 17).

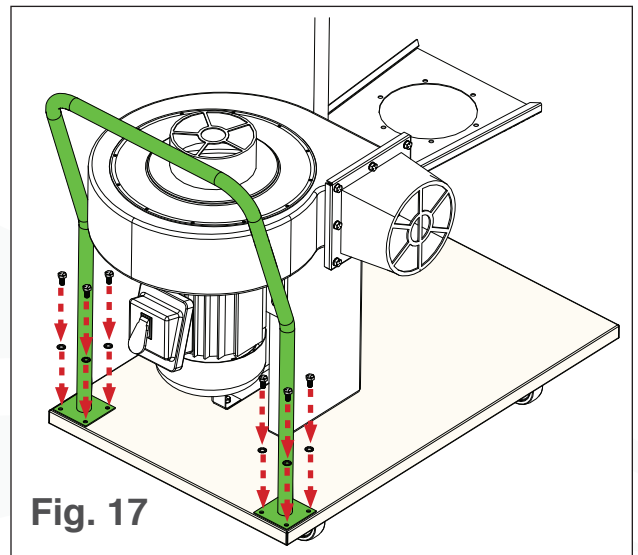

Fig. 17

## Step 9: Attach the Cyclone and Bin Lid to the Lid Holder

1. Open fastener bag H. Bag H contains:
  - Six ¼"–20 x 1" Hex Head Bolts\*
  - Twelve ¼" Flat Washers
  - Six ¼" Silicone Washers
  - Six ¼"–20 Nyloc Nuts.
2. Align the cyclone and cyclone/lid gasket with the large hole in the lid holder (see Fig. 18). The cyclone can be oriented in six 30° increments. For easiest operation, the cyclone inlet may face anyway **except that of the filter adapter** (see Fig. 19).
3. Place all six bolts through six of the flat washers, then through the cyclone, gasket, and lid holder (see Fig. 18).
4. Align the stainless bin lid other cyclone/lid gasket with the underside of the lid holder (see Fig. 20).
5. Secure the silicone washers, then the flat washers and nuts over the ends of the bolts (see Fig. 20).

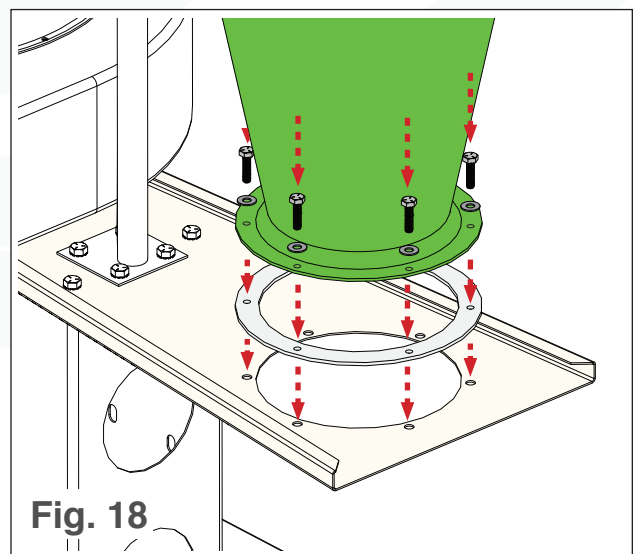
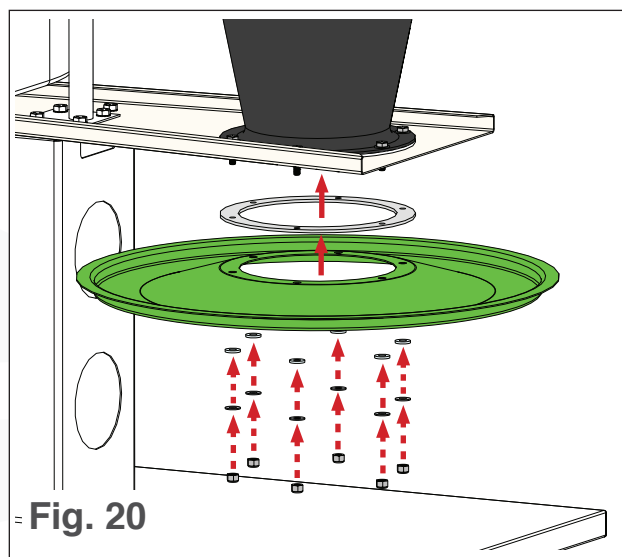
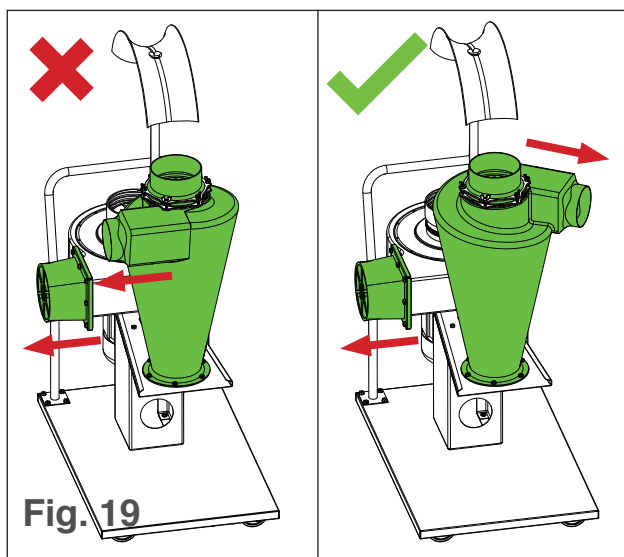

Fig. 18

\*The bolts, metal washers, and nuts used for this step are stainless steel. Ensure only these fasteners are used for this step.



## Step 10: Attach the Bin

1. Place the lower lid gasket around the stainless steel bin lip.
2. Slide the bin under the bin lid (see Fig. 21).
3. Attach the bin to the lid using all four bin latches (see Fig. 22).

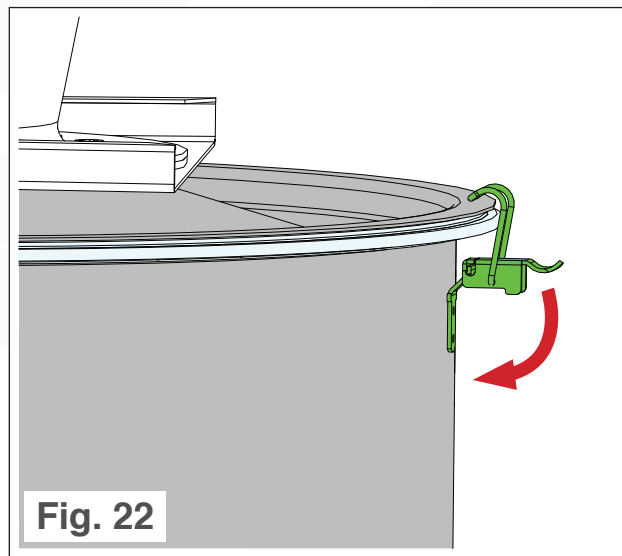
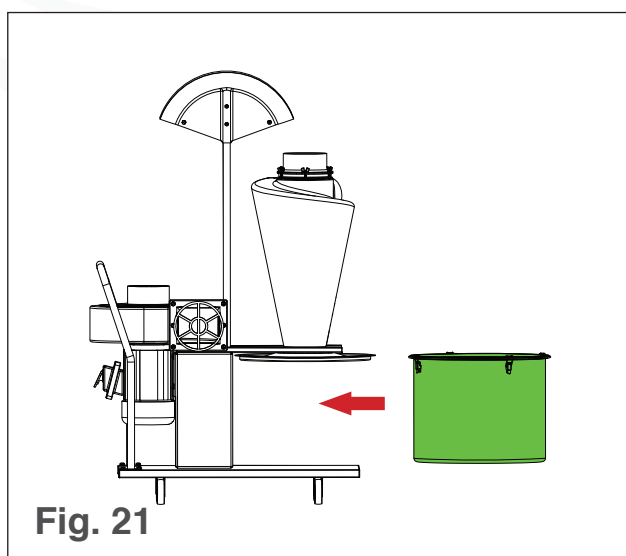

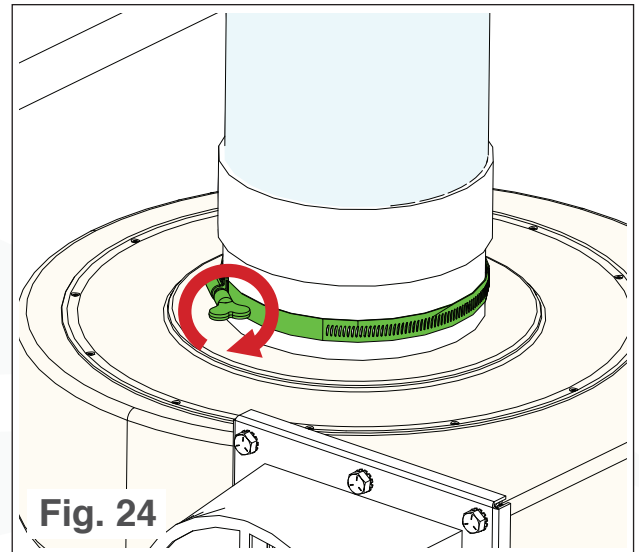
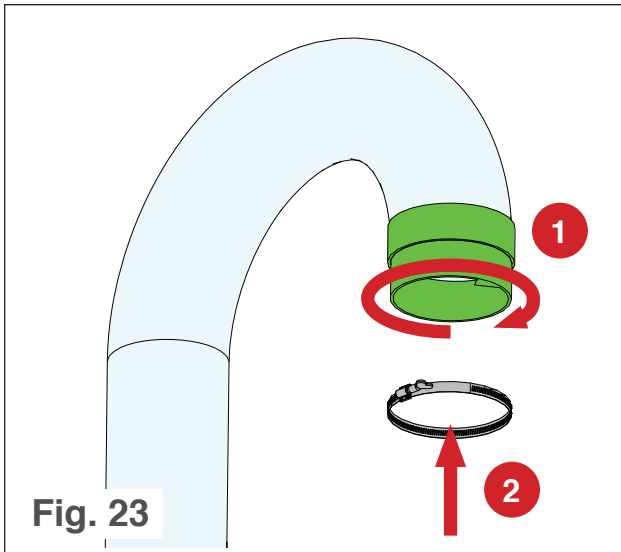

## Step 11: Attach the Motor Assembly-to-Cyclone Hose

1. Apply isopropyl alcohol to the ends of the 6" hose. This will make screwing on the hose cuffs easier.
2. Screw a 6" hose cuff on each end of the hose (see Fig. 23)
3. Slide a 6" hose clamp over each hose cuff (see Fig. 23).
4. Apply isopropyl alcohol or dish soap to the cyclone outlet. This will make sliding on the hose cuff easier.
5. Slide one hose cuff over the cyclone outlet and the other over the motor assembly inlet.
6. Tighten both hose clamps (see Fig 24).

## Step 12: Attach the Filter Bags to the Filter Adapter

1. Place the 70 micron filter bag (the coarser bag) inside the 40 micron filter bag.
2. Place the 7" filter bag clamp around the filter bag opening.
3. Slide the filter bag opening over the filter adapter (see Fig. 25).
4. Tighten the filter bag clamp.

## Step 13: Attach the Cyclone-to- Trimmer Hose

1. Apply isopropyl alcohol to the ends of the 5" hose.
2. Screw the 5" hose cuffs on the ends of the hose.
3. Slide a 5" hose clamp over one hose cuff.
4. Apply isopropyl alcohol or dish soap to the cyclone inlet.
5. Slide the hose cuff and hose clamp over the cyclone inlet.
6. Tighten the hose clamp.

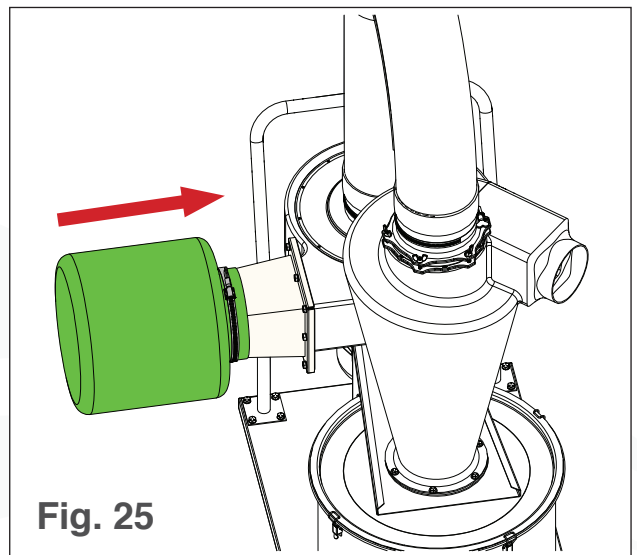

Fig. 25

## Step 14: Attach the Trim Saver to the T4 Trimmer

1. To attach the Trim Saver to the T4 trimmer, follow the **Initial Setup** instructions in the *T4 User Manual*.

To ensure optimal performance of the Trim Saver, the following inspections should be made on a weekly basis\*.

**Ensure the Trim Saver and T4 are unplugged and all motors have come to a complete stop before conducting any inspections.**

1. Inspect the filter bags for any wear or damage.
2. Ensure the filter bags are not blocked.
3. Inspect the hoses for small holes in the ribs.
4. Inspect the lower lid gasket for tears.
5. Ensure the hose clamps are tight around the hose cuffs.
6. Once a year, inspect the impeller blades for damage (see step 7 on page 24).

*\*Except for inspecting the impeller. Only inspect the impeller once a year or as a troubleshooting solution.*



# DANGER

**TURN OFF ALL MOTORS, THEN  
UNPLUG THE TRIM SAVER  
AND T4 BEFORE CONDUCTING  
INSPECTIONS.**

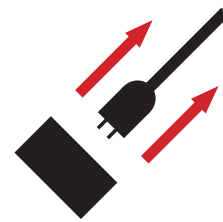

# CLEANING

To ensure optimal performance, the Trim Saver should be cleaned regularly using the following steps:

## Step 1: Disassemble the Trim Saver

1. Ensure the Trim Saver and trimmer have been safely switched off and disconnected from power using your facility's lockout procedure.
2. Cover the end of the plug to prevent water damage and electric shock.
3. Detach the Bin:
  - a. Release the four bin latches.
  - b. Slide the bin out from under the bin lid.
  - c. Remove the lower lid gasket from the top of the bin (see Fig. 26).
3. Detach the Hoses:
  - a. Loosen the hose clamps around both hose cuffs on both hoses (see Fig. 27).

 **DANGER**

**ENSURE THE TRIM SAVER IS UNPLUGGED AND THE PLUG IS COVERED BEFORE CLEANING TO PREVENT ELECTRIC SHOCK!**



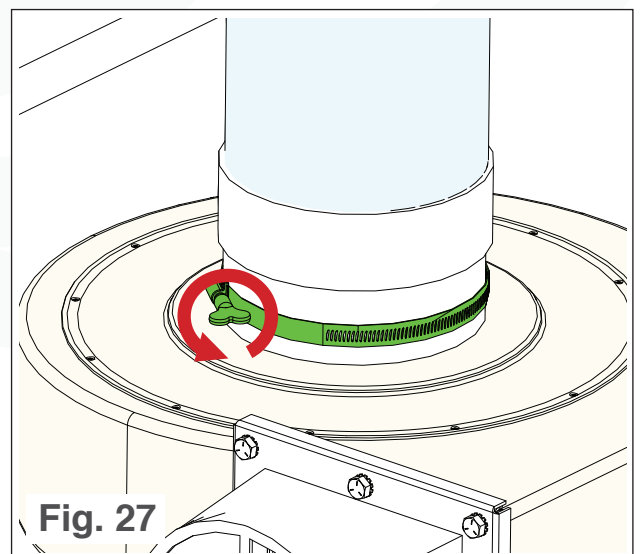
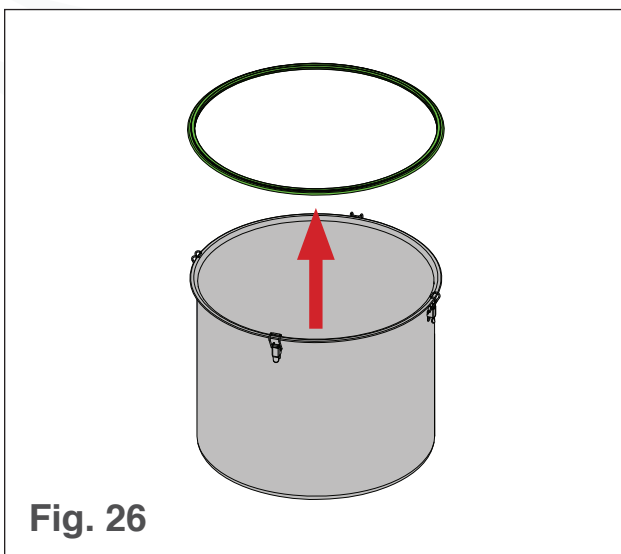

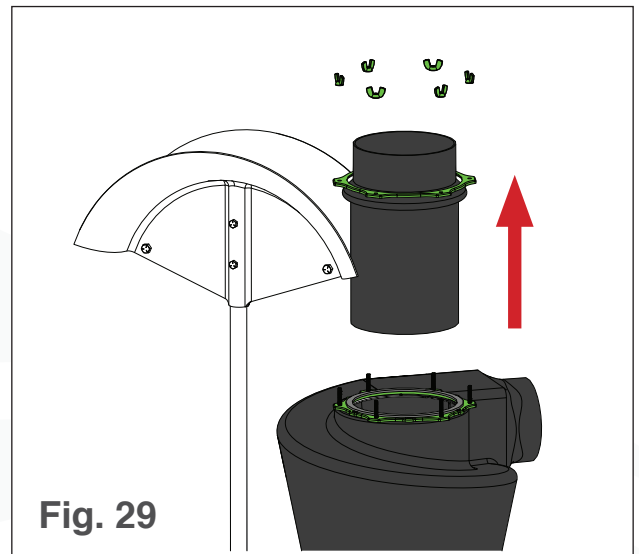
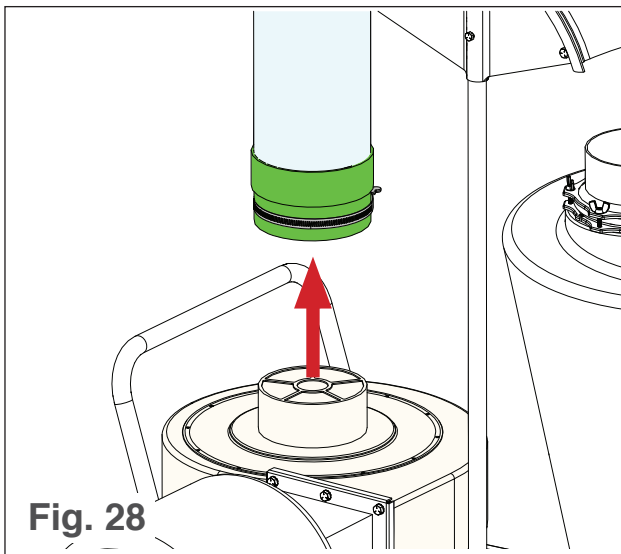

- b. Pull the hose cuffs free from the inlets and outlets (see Fig. 28).
  - c. Unscrew the hose cuffs from the hoses.
4. Detach the Cyclone Outlet:
- a. Remove all six wing nuts from the cleaning flange (see Fig. 29).
  - b. Remove the cyclone outlet and cleaning flange (see Fig. 29).
5. Detach the Filter Bags:
- a. Loosen the filter bag clamp.
  - b. Pull the filter bags off the filter adapter (see Fig. 30)
  - c. Remove the 70 micron filter bag from the 40 micron filter bag.

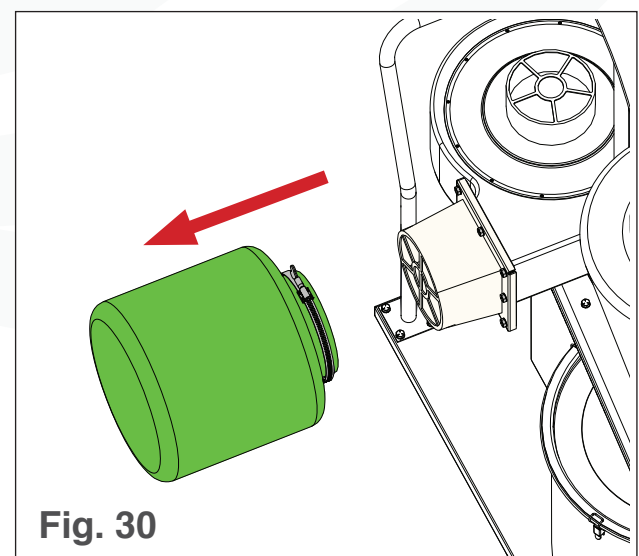

If using an UltraClean to clean the Trim Saver, conduct the following extra disassembly steps:

- 6. Detach the cyclone:
  - a. Remove the six bolts and nuts

securing the cyclone and bin lid to the lid holder (see Fig. 31).

- b. Remove the cyclone, bin lid, and gaskets.

## Step 2: Clean the Trim Saver

The Trim Saver can be cleaned manually, or it can be left to clean in the Twister UltraClean ultrasonic cleaning system.

### Manual Cleaning

1. Clean the small, removable components:
  - a. Soak the filter bags, lower lid gasket, cyclone outlet, and cyclone outlet gasket in a bucket of water and detergent for five minutes.
  - b. Agitate the components to remove any product.
  - c. Remove the components from the liquid and rinse them.
  - d. Allow the components to dry.
  - e. Spray the components with isopropyl alcohol or another sanitizer\*.
  - f. Allow the components to dry.
2. Clean the hoses and cyclone:
  - a. Remove any large, easy-to-remove pieces of product from the hoses and cyclone.
  - b. Spray the inside and outside of the hoses and cyclone with a foaming detergent.  
**Do not spray the motor assembly or electrical components.**
  - c. Allow the detergent to sit for five minutes.
  - d. Repeat steps **b** and **c** as necessary.

\*Not all sanitizers are compatible with the filter bags and other plastic components. Test sanitizers for chemical compatibility with the bags and plastic components before washing.

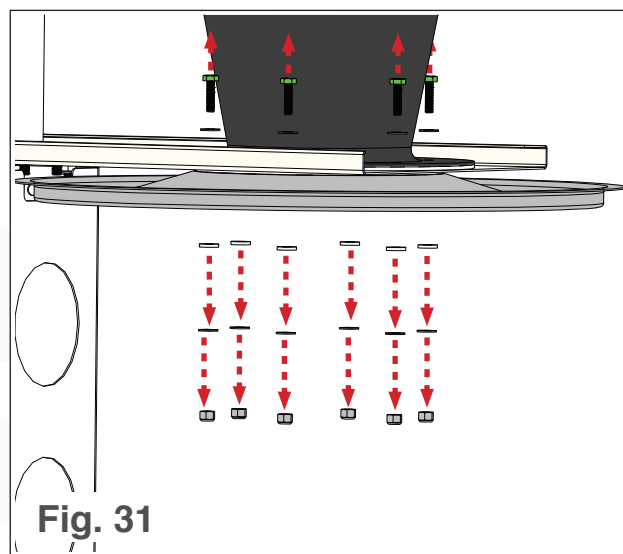



- e. Rinse the hoses and cyclone. **Do not rinse the motor assembly or electrical components with water.**
- f. Spray the hoses and cyclone with isopropyl alcohol or another sanitizer.
- g. Allow the sanitizer to evaporate.

### UltraClean Cleaning

1. Clean only the removed components in the UltraClean (see the *UltraClean User Manual*).

### Step 3: Reassemble the Trim Saver

1. To reassemble the trim saver, perform all the disassembly steps in reverse.

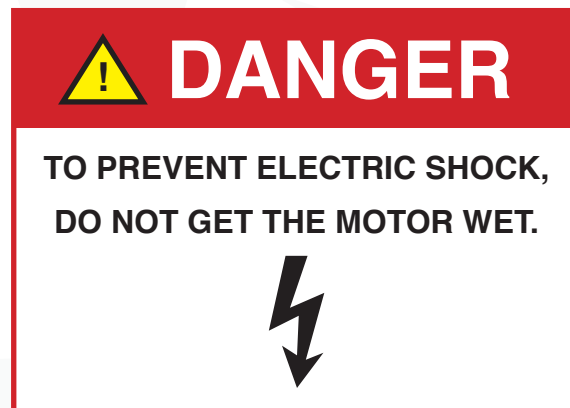

# TROUBLESHOOTING

If any problems not listed in this section arise, or any troubleshooting solutions do not solve the problem, contact Keirton technical support for assistance (see **Contact Us** on page 30).

## Product is Not Exiting the T4 Tumbler

### Possible Causes:

- The T4 is not inclined enough.
- The suction is too high.

### Solution:

1. Ensure the Trim Saver and T4 are unplugged and all motors have come to a complete stop.
2. Increase the T4's tilt.
3. If increasing the machine's tilt does not solve the problem, purchase a Vacuum Bypass to reduce suction (see **Bypass** on page 29).

## Suction from the Vacuum Seems Weak

### Possible Causes:

- The vacuum outlet is placed too close to a wall.
- The filter bags are dirty.
- The Vacuum Bypass is allowing too much airflow.
- The hose is blocked.
- The gasket connections have leaks.
- There is buildup on the impeller.



# DANGER

**TURN OFF ALL MOTORS, THEN UNPLUG THE TRIM SAVER AND T4 BEFORE CONDUCTING ANY TROUBLESHOOTING.**

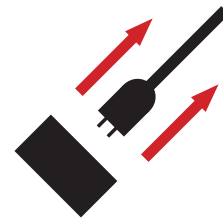

## Solution:

1. Ensure the Trim Saver and T4 are unplugged and all motors have come to a complete stop.
2. If the filter adapter is too close to a wall, relocate the Trim Saver at least 4ft from any wall.
3. If the adapter has plenty of space, inspect the filter bags. If they are dirty, clean them.
4. If the filter bags are clean and a Vacuum Bypass is being used, close the Vacuum Bypass.
5. If the filter bags are clean, ensure nothing is blocking the hose. If a block is found, remove the hose from the T4 and Trim Saver, and remove the blockage.
6. If nothing is blocking the hose, inspect the gaskets for leaks. If leaks are found, replace the gaskets.
7. If all solutions so far have failed, clean the impeller:
  - a. Remove the hose from the motor assembly inlet.
  - b. Remove the 12 screws on the top of the motor assembly (see Fig. 32).
  - c. Remove the top of the motor assembly.
  - d. Scrape buildup off the impeller with a plastic scraper.
  - e. Wipe the impeller with isopropyl alcohol. Do not use water on the impeller. The inside of the motor should remain as dry as possible.



## DANGER

KEEP THE MOTOR AS DRY  
AS POSSIBLE TO PREVENT  
ELECTRIC SHOCK.

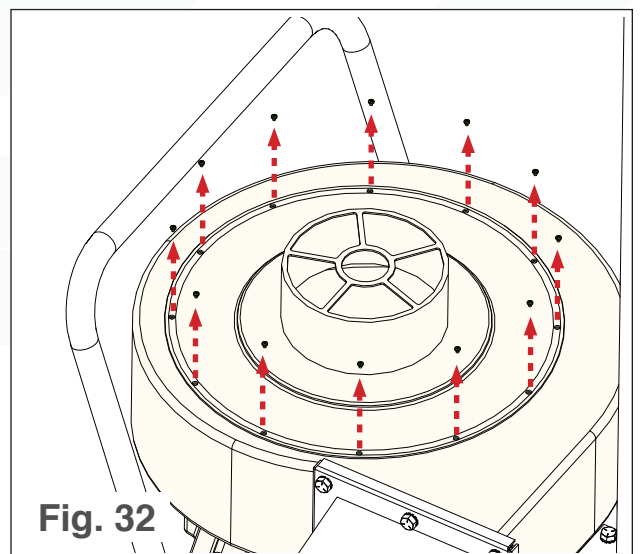

Fig. 32

# WARRANTY INFORMATION

Keirton will repair or replace any parts proven defective in material or workmanship without charge for a period of one year.

The warranty period will begin on the date the machine is purchased by the initial purchaser. The Trim Saver warranty defects can be remedied at any authorized service dealer or directly by Keirton. Any original parts deemed to be defective will be replaced free of charge. Keirton reserves the right to use any manufacturer approved replacement parts for warranty repair.

If warranty repair is required, please contact Keirton at **1-888-254-3204** or **support@keirton.com** and provide the following information:

- Model and serial number (located on the cyclone-facing side of the motor)
- Proof of purchase date
- Copy of the original warranty registration card (unless registration was completed online)
- Details of the defect or problem (including photos and/or video).

Pending approval from Keirton, the machine or defective part must then be returned to Keirton for analysis and replacement. **Do not return the machine to the place of purchase for repair or warranty claims unless you have been authorized by Keirton to do so.** The place of purchase can only sell replacement parts and will not repair warranty issues unless it is noted as an authorized repair dealer and has been authorized to work on your machine.

You may be denied warranty coverage if your machine has failed due to:

- Abuse
- Accidental damage
- Improper maintenance

## WARRANTY INFORMATION

- Improper electrical connection
- Neglect
- Normal wear
- Unapproved modifications including the use of unapproved replacement parts.

Keirton assumes no risk and shall be subject to no liability for damages or loss resulting from the specific use or application made of the product. In no event will Keirton be liable for any special, incidental, or consequential damages (including loss of use, loss of profit, and claims of third parties) however caused, whether by negligence of the manufacturer or otherwise. If you have any questions regarding your warranty rights and responsibilities, please contact Keirton.

The Trim Saver is intended for use on legal aromatic herbs and hops. Please check all municipal, provincial/state, and federal laws and regulations before using the Trim Saver. Keirton does not promote or condone the use of the Trim Saver in any way that may be deemed illegal.

Allow only persons who understand this manual to operate the Trim Saver. Keirton claims no liability for any damage or injury that results from the use of the Trim Saver by persons who have not read and understood the cautions, warnings, and danger notices contained in this manual or through any misuse of the Trim Saver. You are responsible for your safety while operating this machine. **Please keep yourself safe!**

# SPECIFICATIONS

<b>Product Number</b>	Product Number	23-0201-01-P
<b>Operating Conditions</b>	Airflow Capacity	1200CFM
	Operating Conditions	650ACFM @ 5" w.g.
	Static Pressure	10" w.g.
<b>Motor Specifications</b>	Power	1.5hp
	Speed	3450RPM
<b>Electrical Requirements</b>	Input Voltage	120VAC, 60Hz, 1ph
	Circuit Breaker Requirements	15A, 120V
	Connector Plug	NEMA 5-15P (see Fig. 33)
	Current During Start-Up	53A
	Current While Running	12A
	Extension Cord Requirements	12-3AWG (minimum diameter) 50'/15m (maximum length)
<b>Dimensions</b>	Cyclone Inlet Diameter	5"/127mm
	Impeller	10"/254mm
	Machine Height	62"/1.6m
<b>Certifications</b>	Certification	UL, CSA
<b>Filter Bag Materials</b>	200 White Mesh	70 Micron
	300 White Mesh	40 Micron
<b>Sound</b>	Power	80dB
<b>Weight</b>	Machine Weight	155lbs/70kg

**NEMA  
5-15P**

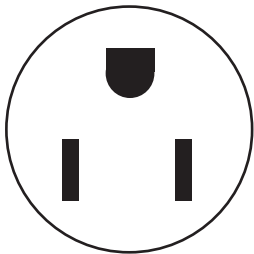

**Fig. 33**

## Bypass

Item	Product Number
T4 Vacuum Bypass	23-0258-00-P

## Cleaning Equipment

Item	Product Number
Twister Foam Cannon	25-0024
Twister UltraClean - North American Three Phase Model	02-10019A
Twister UltraClean - North American One Phase Model	02-10030A

## Spare Parts Kits

Item	Product Number
T4 Trim Saver Gasket Kit	27-10046A
T4 Trim Saver Maintenance Kit*	27-10044A

\*The maintenance kit includes hoses, hose cuffs, hose clamps, filter bags, and a vacuum bypass.

## CONTACT US

Keirton Technical Support is available between 7 a.m. and 7 p.m. Pacific Standard Time seven days a week at:

- **1-888-254-3204**
- **support@keirton.com**





